

Contents

1.	PURPOSE	2
2.	FIELD OF APPLICATION	2
3.	Definitions/Abbreviations.....	2
4.	The Pole	3
4.1	Dimensions	3
4.2	Specifications	4
4.3	Functionality	5
4.4	The user interface	6
4.5	Operation	7
4.5.1	Introduction	7
4.5.2	Charging.....	7
4.5.3	Exceptions.....	12
	Appendix A	15

1. PURPOSE

The purpose of this document is to describe how to use the equipment named JUICE POLE.

2. FIELD OF APPLICATION

It is used to document how to use such equipment as part of an Electric Vehicle Charging System.

3. Definitions/Abbreviations

PS 4G	POLE STATION 4G or JUICE POLE 1.1
JP	POLE STATION 4G or JUICE POLE 1.1
EV	ELECTRIC VEHICLE
RH	RIGHT
LH	LEFT
CM	COMMUNICATION MODULE
CP	CONTROL PROCESS

4. The Pole

4.1 Dimensions

There are several versions of the JUICE POLE:

1. Three-phase/Three-phase with 2 T2 sockets;
2. Single-phase/Three-phase with 1 T3a socket and 1 T2 socket;
3. Single-phase/Single-phase with 2 T3a sockets.

These variants affect the user, especially regarding the type of power supply cable provided with the Electric Vehicle.

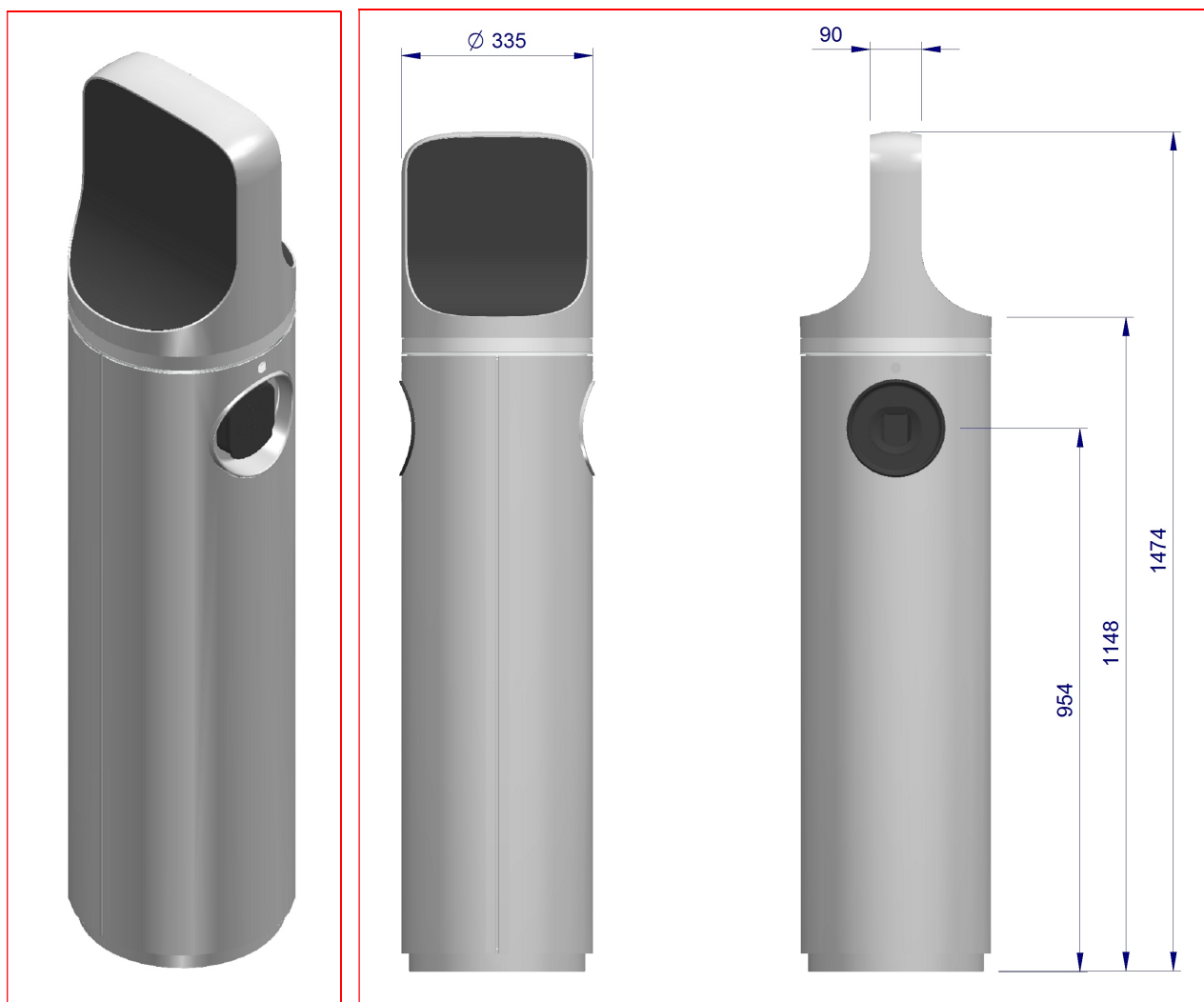

3/4 view

Outline and dimensions in mm

4.2 Specifications

POWER SUPPLY:

Voltage: 400 Vac Three-phase
Frequency: 50 Hz

CHARGING DATA:

SINGLE-PHASE CHARGING:

Type 3A socket with 4 contacts: L, N, EARTH + Pilot

Maximum power: 3.7 kW

Maximum current: 16 A

Thermal-magnetic protection:

$I_n = 16 \text{ A}$

$I_{cn} = 10 \text{ kA}$

Type "D"

Residual Current Protection:

Current = 0.03 A

Protection type B

THREE-PHASE CHARGING:

Type 2 socket with 7 contacts: R, S, T, N, EARTH + Pilot + Proximity

Maximum power: 22kW

Maximum current: 32A

Thermal-magnetic protection:

$I_n = 32 \text{ A}$

$I_{cn} = 10 \text{ kA}$

Type "D"

Residual Current Protection:

Current = 0.03 A

Protection type B

GENERAL:

Ambient temperature: -30° to +50°C

Relative humidity: 5% to 95%

Atmospheric pressure: 860 hPa to 1060 hPa

Protection level: IP54

STANDARDS:

EN61851-1

EN61851-22

EN62196-1

4.3 Functionality

The JUICE POLE was designed for charging "Class I" Electric Vehicles.

It supplies 230 Vac single-phase with a maximum power of 3.7 kW and/or 400 Vac three-phase with a maximum power of 22 kW.

It works in "Mode 3" and is connected to the vehicle as described in the EN61851-1 standard (Ed. 3.0) under "**Case A**" or "**Case B**".

Class I	An Electric Vehicle the protection of which against electric shocks, when connected to an a.c. supply network (mains), does not rely on the functional insulation, but includes supplementary safety measures. This shall consist of connecting all exposed conductive parts to the vehicle earth terminal.
Mode 3	Direct connection of the Electric Vehicle to the mains power. Any battery chargers are installed directly on the vehicle.
Case A	Connection of an Electric Vehicle to an a.c. supply utilizing a cable and plug permanently attached to the Electric Vehicle.
Case B	Connection of an Electric Vehicle to an a.c. supply utilizing a detachable cable assembly with a vehicle connector and a.c. supply equipment.

N.B. The user should note that the "pilot control wire" in the power supply circuit prevents the Juice Pole from supplying power until the plug is fully inserted into the socket.

4.4 The user interface

The JUICE POLE is equipped as described below.

Description	Use
Display	Provides the user with information
User Card Reader	Reads the user's card
RH indicator	Always lit
LH indicator	Always lit
RH socket	RH supply point
LH socket	LH supply point

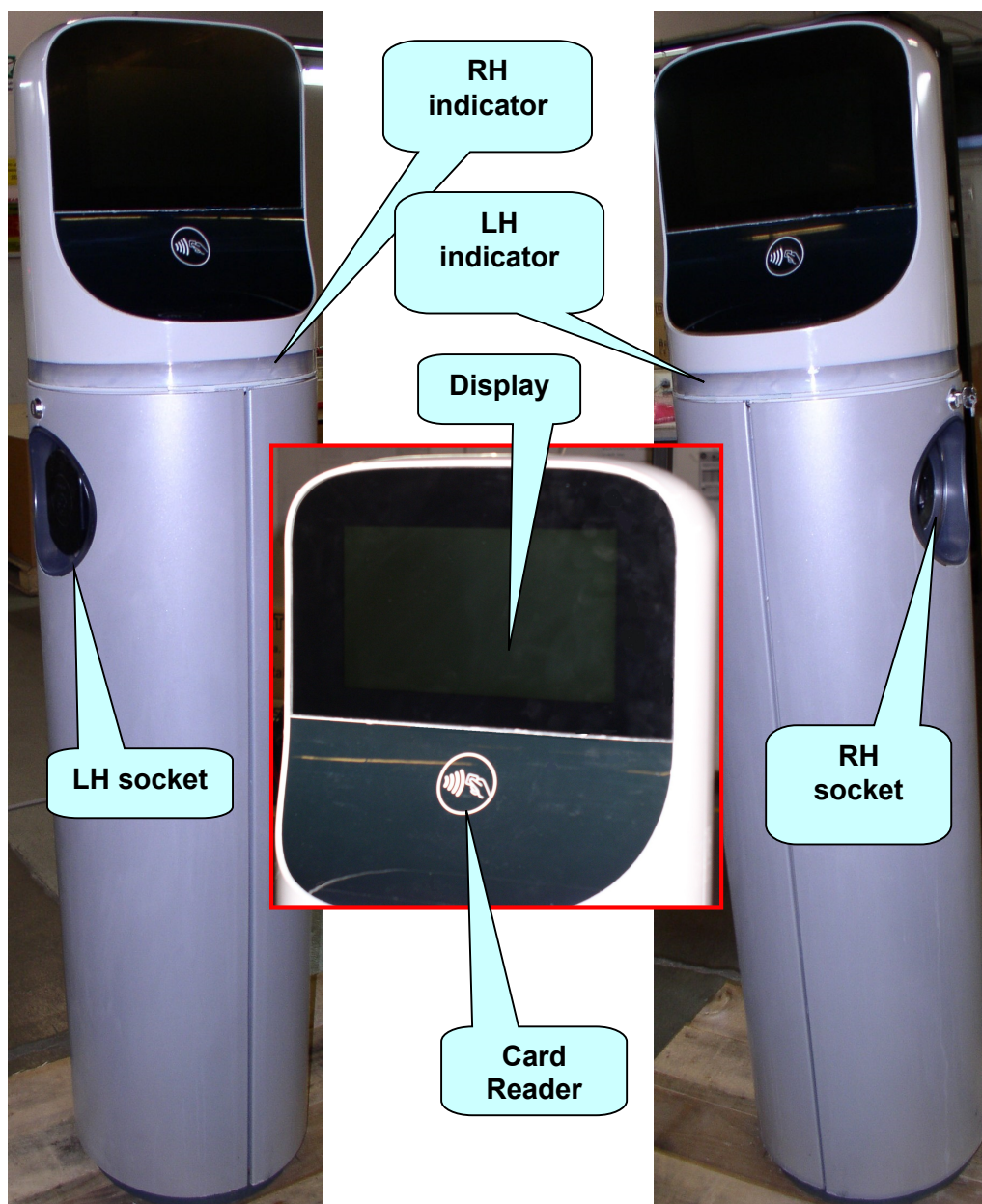

4.5 Operation

4.5.1 Introduction

The JUICE POLE control system manages both the RH and LH sockets in parallel, making it possible to charge two EVs simultaneously.

4.5.2 Charging

The display initially looks like this (assuming that there is no charging in progress):

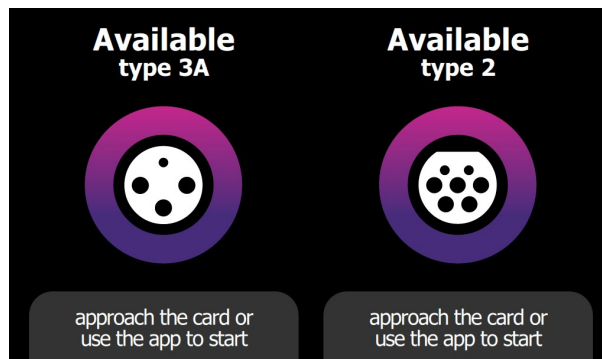

First, users must identify themselves with the RFID card or appropriate APP.

Bring the RFID card up to the reader and wait for it to be accepted. When this happens, the following screen will appear on the display for a moment:

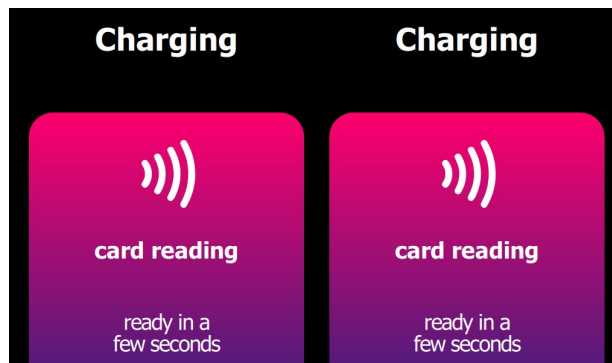

If the system accepts the RFID card, this appears:

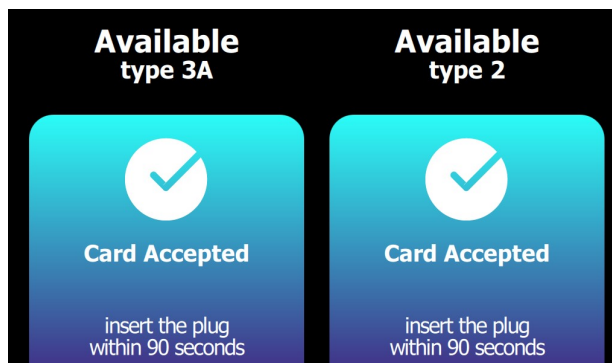

It is then necessary to insert the plug on the charging cable into the chosen socket within 90 seconds (timeout).

The following screens will "alternate" cyclically.

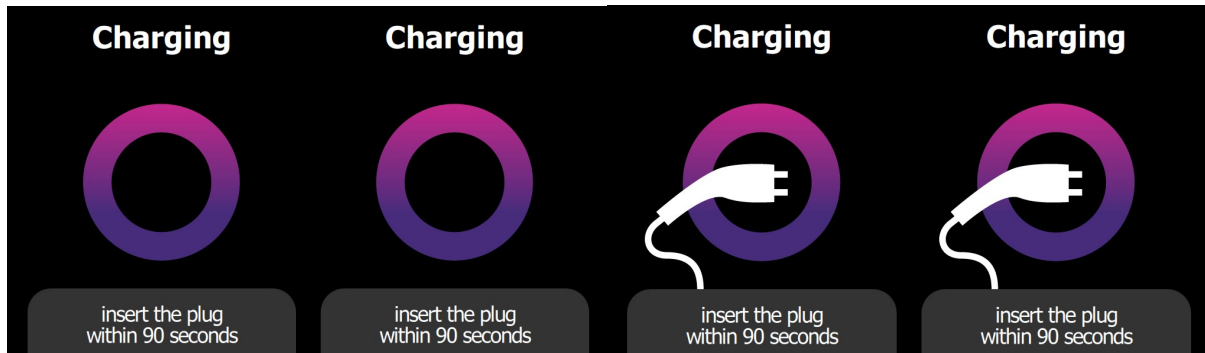

When only 30 seconds remain, the screen will show a numerical countdown (see the red arrow).

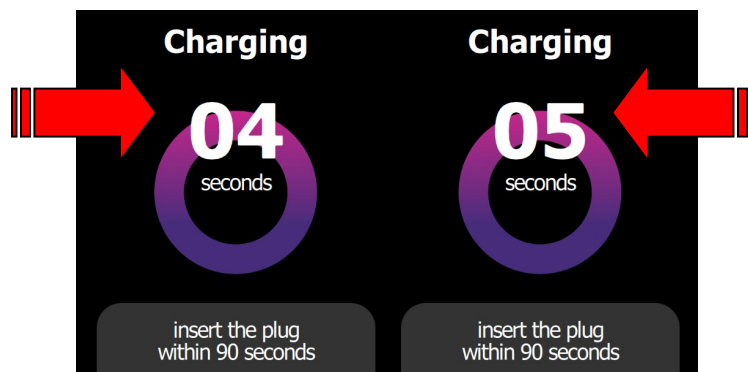

Suppose we insert the plug into the RH side; the display will show:

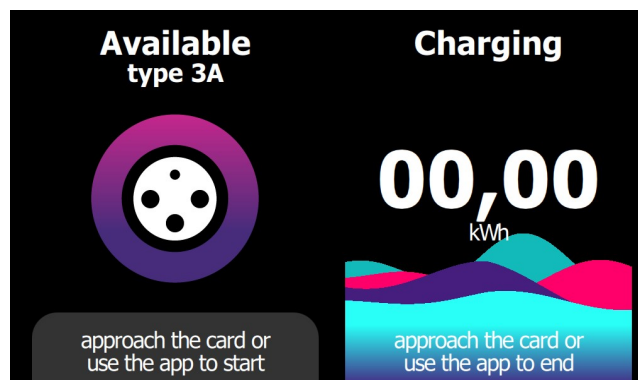

As soon as charging starts, the screen will show the kWh supplied on the side in which the plug is inserted, e.g. RH.

If a second valid RFID card is brought up to the reader (or using an appropriate APP) while the charging just started is in progress, the following appears in sequence:

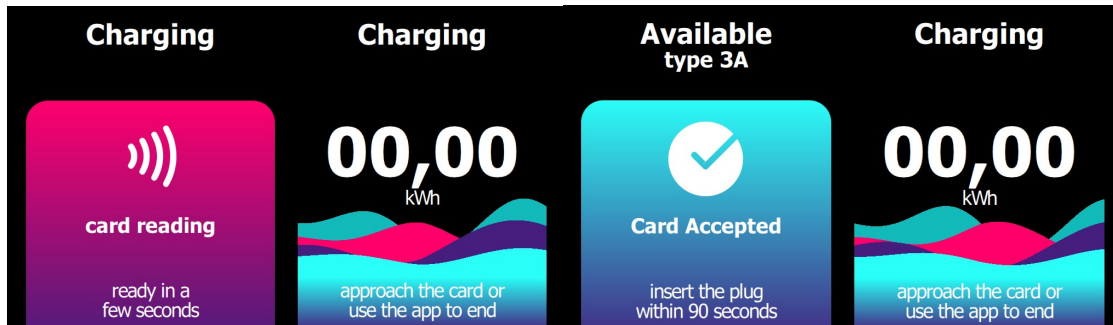

It is now necessary to insert the plug on the charging cable into the LH socket (last available) within 90 seconds (timeout). The screen with a socket that appears/disappears will be shown only for the LH side.

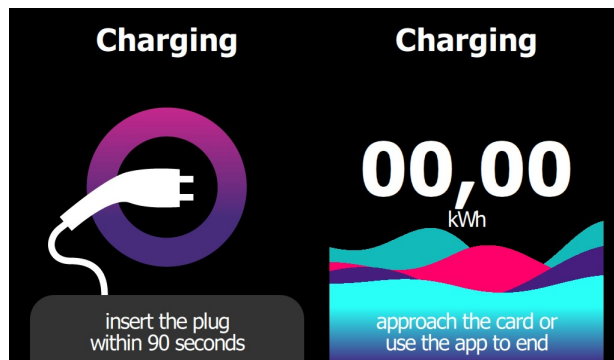

As soon as charging starts, the display will show the kWh supplied on the LH side in which the plug is inserted.

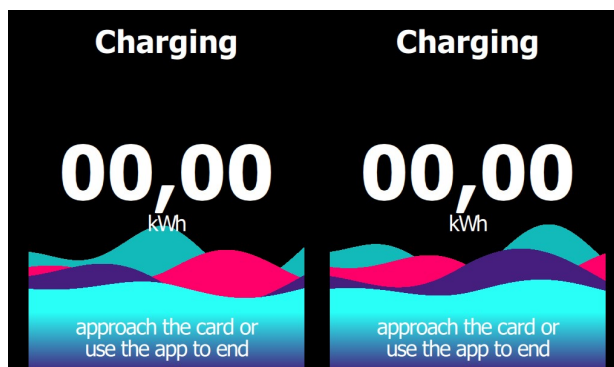

Suppose that the charging on the RH side is stopped by bringing the card up to the RFID reader (or using the appropriate APP); the following will appear in sequence:

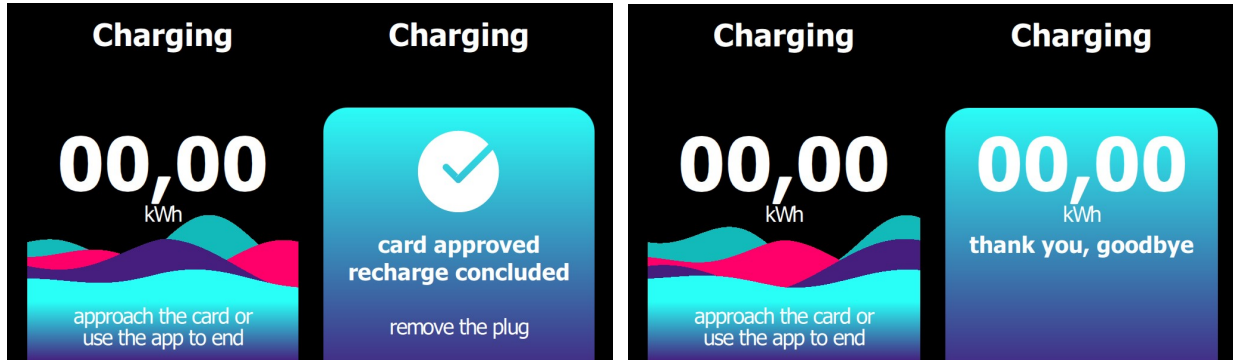

The system will stop supplying power from the side corresponding to the RFID card used, and gives a summary of the Wh supplied during charging. It is now necessary to extract the plug on the RH side.

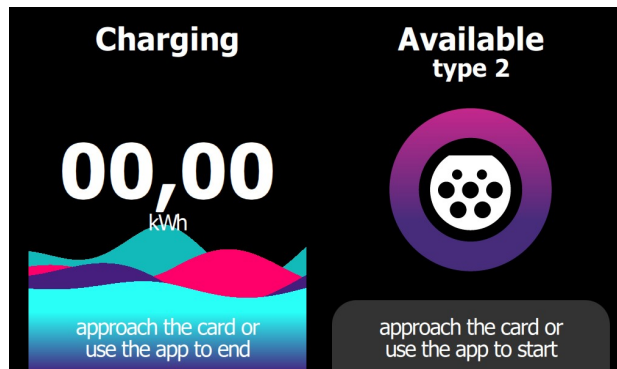

The RH plug will become available for charging again.

Lastly, suppose that the charging on the RH side is also terminated by bringing the card up to the RFID reader; the following will appear in sequence:

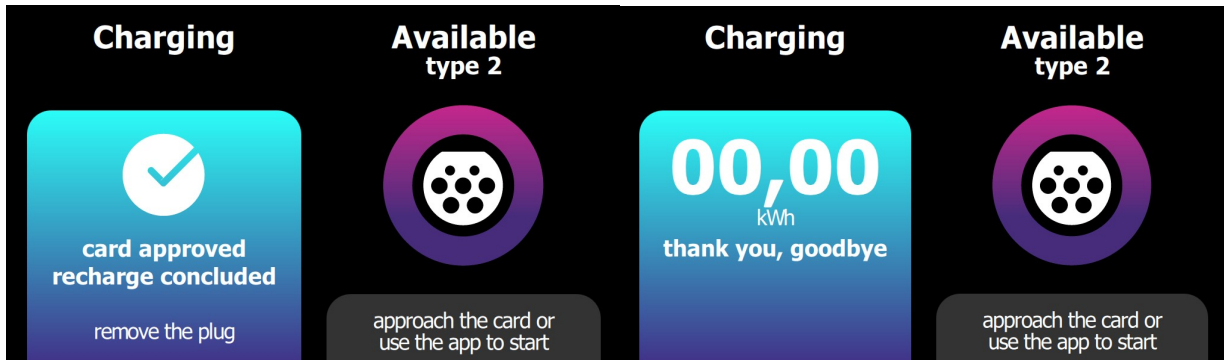

The system will stop supplying power from the side corresponding to the card used, and gives a summary of the Wh supplied during charging. It is now necessary to extract the plug on the LH side.

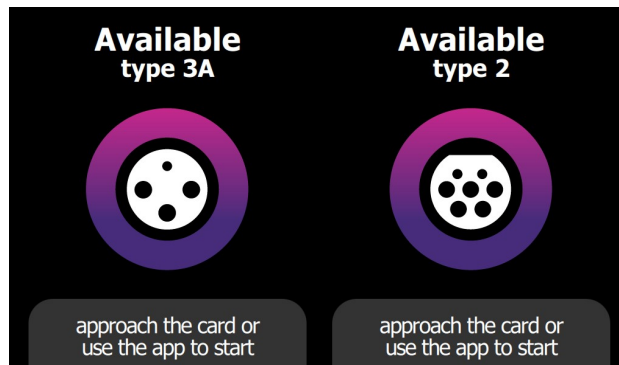

Both sockets are now available for charging again.

4.5.3 Exceptions

During the activities described in the previous paragraph, the system may respond to the user in an unexpected manner. In this case, the user must perform specific actions to solve the setback, if possible.

Obviously, exceptions related to user card "validation" by the centre do not regard the APP, which communicates directly with it.

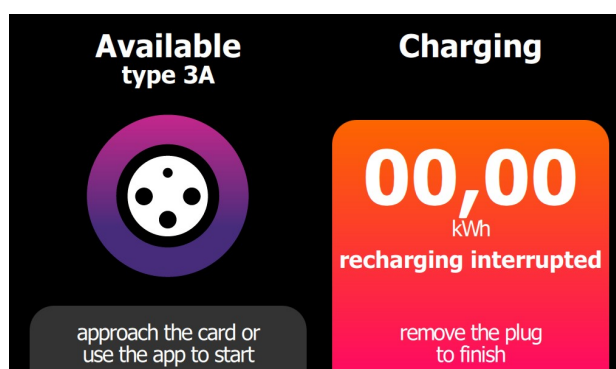

- Recharging interrupted → Remove the plug to finish.

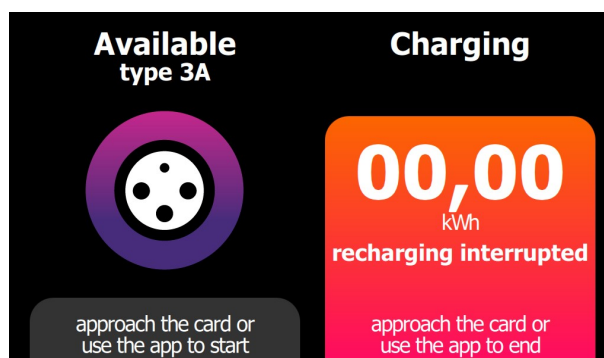

- Charging interrupted → Approach the card or use the App to end.

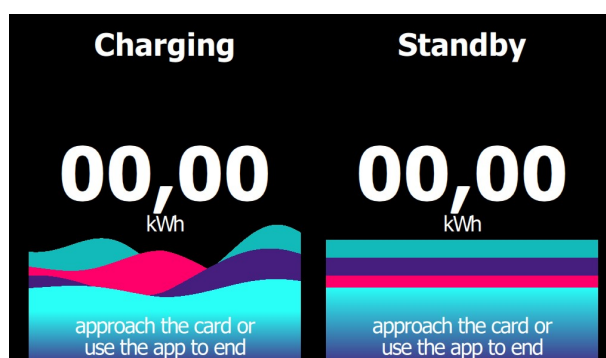

- Standby: charging suspended by the centre → Wait for charging to continue.
- Standby: charging suspended by the EV (batteries overheated) → Wait for charging to continue.
- Standby: charging suspended by the EV (batteries charged) → Remove the plug.

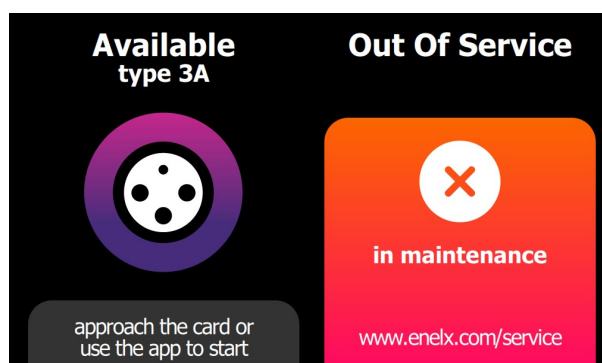

- Plug inserted without card validation → Remove the plug

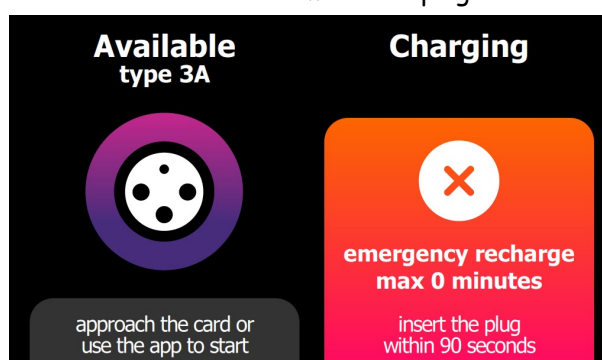

- Communication problems with the centre → Charging will end when the indicated time expires if the communication problems are permanent (e.g. 15 minutes).

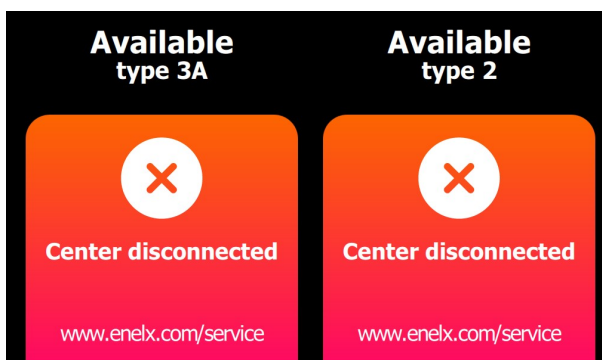

- (105:) Problems with the centre → Not possible to continue.

The messages are coded as follows:

100: Invalid card

- → Not possible to continue.

101: Validation not successful

- → Not possible to continue.

103: Validation failed

- Problems with the centre → Not possible to continue.

105: Centre disconnected

- Communication problems with the centre → Not possible to continue.

106: Session limit reached	<ul style="list-style-type: none"> → Not possible to continue.
107: Unrecognised error	<ul style="list-style-type: none"> → Not possible to continue.
108: CU not registered	<ul style="list-style-type: none"> Problems with the centre → Not possible to continue.
109: Commissioning error	<ul style="list-style-type: none"> → Not possible to continue.
200: Unauthorised card	<ul style="list-style-type: none"> Card problems → Not possible to continue.
201: Expired card	<ul style="list-style-type: none"> Card problems → Not possible to continue.
202: Unrecognised card	<ul style="list-style-type: none"> Card problems → Not possible to continue.
203: Unregistered card	<ul style="list-style-type: none"> Card problems → Not possible to continue.
204: Card not accepted	<ul style="list-style-type: none"> Card problems → Not possible to continue.
205: Card accepted	<ul style="list-style-type: none"> Card problems → Not possible to continue.
206: Credit finished	<ul style="list-style-type: none"> Invalid card → Not possible to continue.
207: Card already being used	<ul style="list-style-type: none"> → Not possible to continue.
208: Invalid contract	<ul style="list-style-type: none"> Invalid card → Not possible to continue.
209: No associated stakeholder	<ul style="list-style-type: none"> Invalid card → Not possible to continue.
210: Incorrect CU type	<ul style="list-style-type: none"> Invalid card → Not possible to continue.
211: Incorrect POD	<ul style="list-style-type: none"> Invalid card → Not possible to continue.
212: Out of province	<ul style="list-style-type: none"> Invalid card → Not possible to continue.
214: Socket booked	<ul style="list-style-type: none"> → Not possible to continue.

Appendix A

Error codes

Messages appear on the display together with an "Error Code" (see the blue arrow) if errors occur during normal JUICE POLE operation.

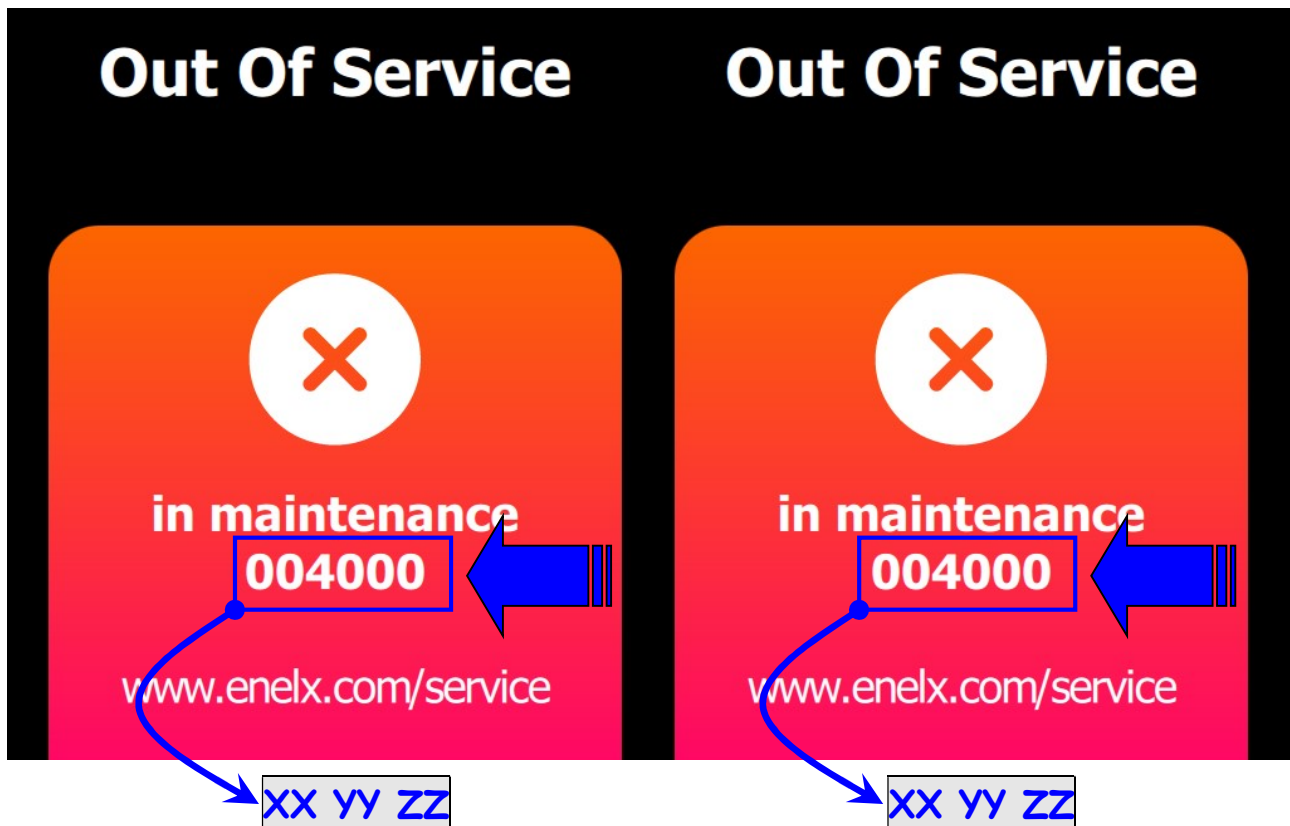

The table below lists all the possible error codes with their meanings and possible solutions.

X	X	Y	Y	Z	Z	Event	Solution
0	#	#	#	#	#	Pole Station Identifier	
4	#	#	#	#	#	The system is powering down	Restore the power supply
#	2	#	#	#	#	CM is not operational	Switch the PS off and on again
#	4	#	#	#	#	Internal flash memory full	Ask the centre to erase it
#	6	#	#	#	#	CM is not operational + Internal flash memory full	Switch the PS off and on again + Ask the centre to erase
#	8	#	#	#	#	No mains power	Restore the power supply
#	A	#	#	#	#	CM is not operational + No mains power	Switch the PS off and on again
#	E	#	#	#	#	CM is not operational + Internal flash memory full + No mains power	Switch the PS off and on again + Ask the centre to erase
#	#	1	#	#	#	Communication problem with the card reader	Switch the PS off and on again
#	#	2	#	#	#	Communication problem with the meter	Switch the PS off and on again
#	#	4	#	#	#	Equipment opening detected (Antitamper)	Ask the centre for a reset
#	#	5	#	#	#	Communication problem with the card reader + Equipment opening detected (Antitamper)	Switch the PS off and on again + Ask the centre for a reset
#	#	#	#	1	#	Communication problem with the socket board	Switch the PS off and on again
#	#	#	#	2	#	Internal residual current device or circuit breaker tripped	Rearm the circuit breaker
#	#	#	#	#	1	No communication with the power supply board	Switch the PS off and on again
#	#	#	#	#	2	CP is not operational	Switch the PS off and on again
#	#	#	#	#	3	CP is not operational + No communication with the power supply board	Switch the PS off and on again

N.B. "# " means "any value".